



Accreditation by RvA  
MGMT. SYS.  
RvA C 449  
Reg. No PPCE-0091-0593

ISO 9001:2000



**VIRAJ  
PUMPS**

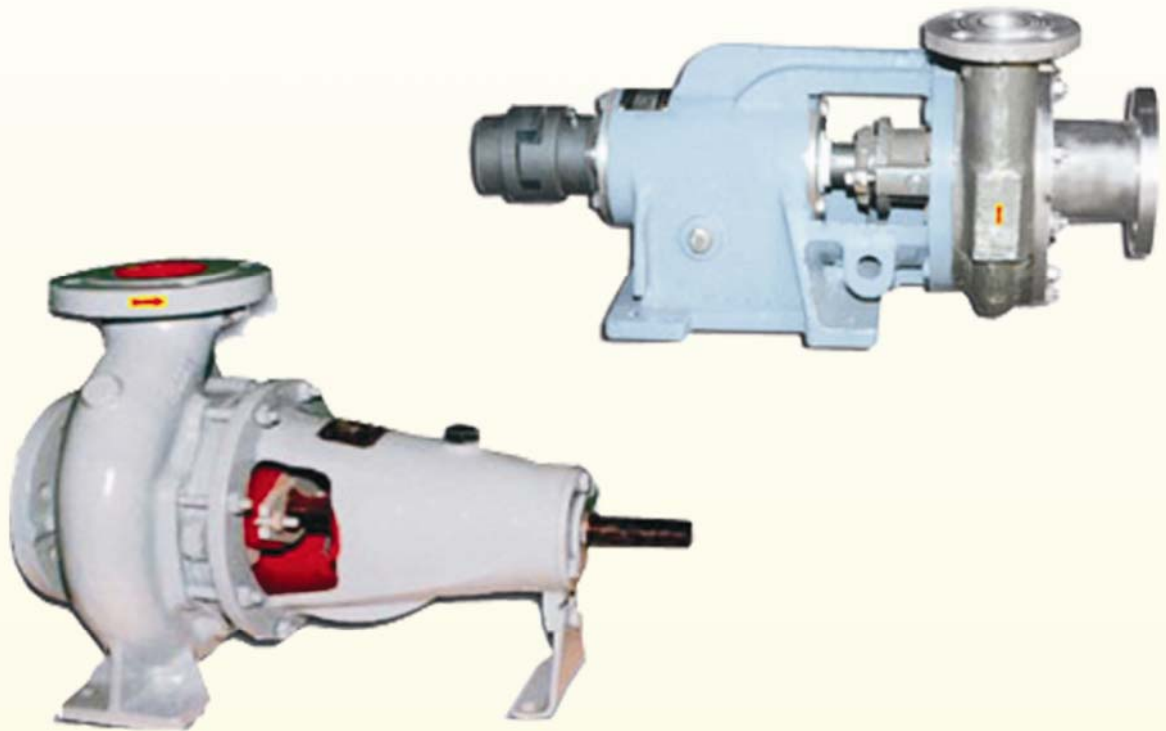

## **HORIZONTAL CENTRIFUGAL ENG-SUCTION/PROCESS PUMP VCCP SERIES**

*If there is liquid  
There is "Viraj"*



# "VIRAJ" HORIZONTAL CENTRIFUGAL END-SUCTION/PROCESS (VCCP SERIES)

The "VCCP" Series Horizontal Centrifugal Radial Split Back-Pull out design pump consisting of 26 Model with Two Group of Bearing Housing for Minimum Inventory of spares and reducing maintain problem. Standard design is foot mounted with centre line mounting . This series are trouble free End-Suction type centrifugal which allows selection of a suitable model for any demand . Highest precision standards and specialized up to date manufacturing method, are combine to produce "VIRAJ" pump quality and complete dependability. The exclusive and valuable feature of these pumps, provide long and trouble free service. The Shaft, Impeller, or gland all "VIRAJ" pump parts , behave been engineered to give extra service and performance with the greater reliability.

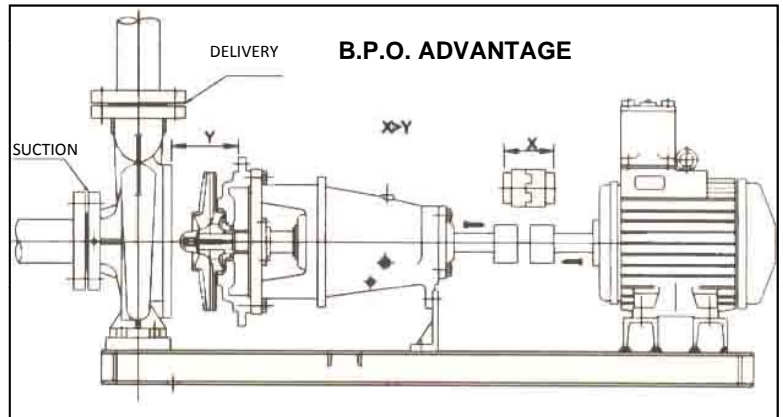
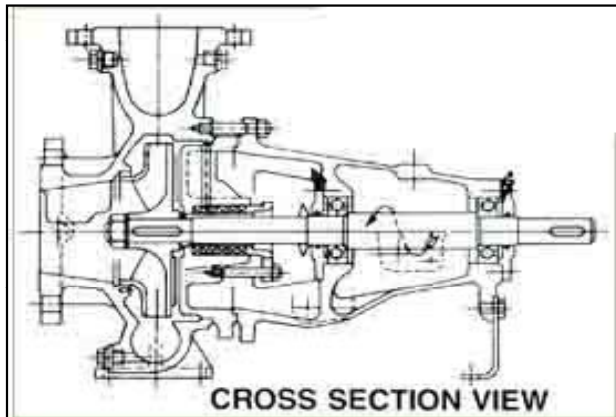

OPERATING RANGE	
CAPACITY	: UP TO 300 M3/HR.
TOTAL HEAD	▶ UP TO 130 MTR.
SIZE	▶ 25 TO 250 MM
PRESSURE	▶ UP TO 40 KG/CM2
REC. SPEED	: 2900 RPM & 1440 RPM
REC. POWER	: UP TO 90 KW
TEMPERATURE	: UP TO 400°C

AVAILABLE CONSTRUCTION
1. C.I.- IS 210 GR. FG 200/260
2. CAST STEEL -ASTMA 216,GR, WCB
3. BRONE-IS 318, GR, LTB-II
4. STAINLESS STEEL-ASTMA 743,CF8M, CF8
5. ALLOY -20, ASTMA 743, CN7
6. CD4MCU /MONEL
7. HESTALLOY "B" & "C"

APPLICATION	
1. WATER SUPPLY	6. PAINT
2. BRINE WATER	7. FIRE FIGHTINE
3. ACID	8. SLOVENTS
4. ALCOHOL	9. THERMIC FLUID
5. PROCESS WATER	10. GENRAL LIQUID

**CASING**  
Single-Stage, Radial split , foot mounted volute casing type with adequate thickness to withstand hydraulic pressure with low radial force. Our model are available with centre line mounting.

**IMPELLER**  
Semi-open & Closed type , Multiple vane Impeller , Impeller with back vane to adjust hydraulic thrust of liquid, Performance are maintained with stable H-Q rising curve, Low NPSH required and ensure smooth working in parallel operation.

**BEARING & LUBRICATION**  
Over Side shaft is supported by ball/angular ball bearing at driving end and non driving use the ball/angular bearing increase the life of pump working hours. Bearing housing also available with cooling arrangement .Oil lubricated pump are protected by oil seal and bearing cover . Labyrinth also we are provided optional in API PUMPS to prevent bearing oil leakage .

**STUFFING BOX**  
Stuffing box available with gland packing system of asbestos, Teflon & carbon considering variable nature of the liquid. Mechanical seal are also accomodable within stuffing box with alternative like balanced. Single & Double seal and tandem seal etc. Flushing & cooling arrange mint also provided as require by customer as per API PLAN.

**B.P.O. ADVANTAGE**  
For the facility of maintenance to dismantle the pump the spacer of the coupling should be removed first then the bearing housing portion together with the impeller can be easily removed without disturbing the motor from the base frame & the volute casing fixd to the pipe line. see figure as above shown in B.P.O. ADVANTAGE.

An ISO 9001 : 2000 Company



## Viraj Electricals

13, Umiya Estate, B/h. Bhikshuk Gruh, Odhav  
Ahmedabad - 38 24 15

Phone : (079) 22974375 :Fax :(079) 22891663,E-mail:virajpump\_girish@dataone.in &viraj\_pump@rediffmail.com